

# MOHAWK 800 SERIES MOBILE COLUMN LIFTS

## 14,000 & 18,000 LB. CAPACITY PER COLUMN



Mohawk's optional mobile jack stands are equipped with large castors for easy movement

MODEL NUMBER	MP-800-014	MP-800-018
Lifting Capacity Per Column:	14,000 lbs.	18,000 lbs.
A. Height of Lift Unit	88.5" (2,248 mm)	
B. Height of Lift Unit at Full Rise	157.125" (3,991 mm)	
C. Width of Lift Unit	44.25" (1,124 mm)	
D. Length of Lift Unit	53.625" (1,362 mm)	
E. Max. Lift Height (4 or more units)	69" (1,753 mm)	
Max. Lift Height (2 units - Wheel Lift Mode)	32" (813 mm)	
F. Min-Max Wheel Diameter	5" - 24.5" (127 - 622 mm)	
Max. Hydraulic System Operating Pressure	2,180 psi	2,600 psi
Lift Speed (Max Load)	60" (1524mm) per min.	
Weight of Lift Unit	1,485 lbs (674 kg)	1,510 lbs (685 kg)
Footprint of Lift Unit	560 sq in. (3,613 sq cm)	
Ground Pressure for each Lift (Max. Load)	27.7 psi (191 kla)	36.6 psi (252 kla)
Turning Radius of Lift Unit	47" (1194 mm)	
Operating Peak Power	4HP	
Operating Voltage	24 VDC Nominal	
Charger Voltage Required	120 VAC @ 60 Hz	
Charger Amps Required	1.3 amps	

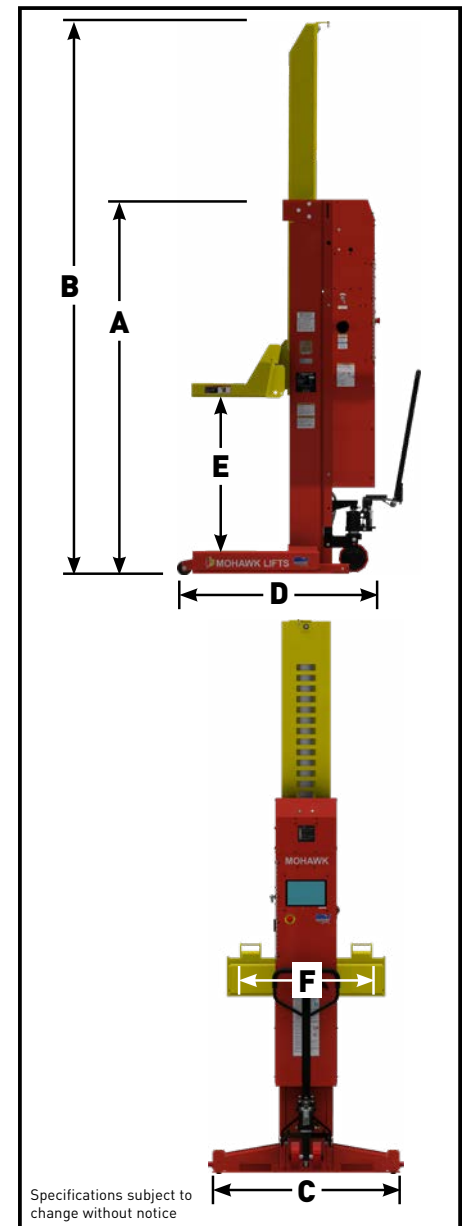

Specifications subject to change without notice

# MOHAWK LIFTS

[www.MohawkLifts.com](http://www.MohawkLifts.com)  
1-800-833-2006

# MOHAWK 800 SERIES MOBILE COLUMN LIFTS

## 14,000 & 18,000 LB. CAPACITY PER COLUMN

### DESIGN FEATURES & BENEFITS

- All columns operate together, individually or can be divided into multiple pairs (2, 4, 6 or 8), with capacities of 56,000 or 72,000 lb for sets of 4.
- Wireless system operates on broad range of channels to limit interference, with multiple frequencies.
- Visual indicator lights show real-time charge level status.
- Utilizes 24 volt operation with built-in 110 volt charging system.
- 69" lifting height in Standard Mode & 32" with two columns in Wheel-Lift mode.
- Hydraulic operation (no screw drives) for safe, efficient, low maintenance, fast & easy lifting.
- Available adapters include 18,000 lb capacity front-to-rear adapter and 15,000 lb capacity forklift adapter.

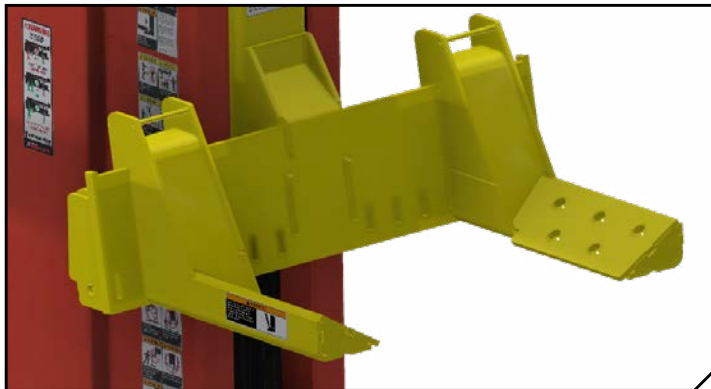

- Adjustable lifting forks accommodate rims from 5" to 24.5".
- Adjustable forks means no wheel reducer sleeves to buy, lose or slip off.
- Positive grip ensures carriage forks stay in place when engaged.
- Low profile fork angle for easy positioning of columns, especially for floatation tires.

### MECHANICAL LOCK LADDER

Safety latch rack engages locks every 2.5" for technicians to set vehicle at optimal working height.



Control from any column on 10" touchscreen, with standard diagnostic and browsing capabilities for quick vehicle troubleshooting.



MADE IN U.S.A.

Retractable wheel design means more steel on the floor for greater stability and industry leading safety.



\* Specifications subject to change without notice

**MOHAWK LIFTS**

Mohawk Lifts, LLC.  
P.O. Box 110  
65 Vrooman Ave  
Amsterdam, NY 12010  
(800) 833-2006  
(518) 842-1431  
FAX: (518) 842-1289  
[www.mohawklifts.com](http://www.mohawklifts.com)

AVAILABLE UNDER DISCOUNTED GOVERNMENT  
CONTRACT IN ALL 50 STATES



### DISTRIBUTED BY:



Ace Service & Installation  
69 Gazza Blvd.  
Farmingdale, NY 11735  
(631) 694-0220  
[www.aceshopequipment.com](http://www.aceshopequipment.com)