

MP-18 SPECIFICATIONS

	MP-18 15" Forks	MP-18 22" Forks
Capacity: Capacity per post	18,000 lbs.	16,000 lbs.
Lifting speed:	66 sec.	66 sec.
Motor rating (per column):	2.5 H.P.	2.5 H.P.
Standard power requirement:	208/240 V or optional 440/480 V 3 phase (single phase option available) OR 24 volt DC operations	
Amperage requirement:	10 AMPS (per post AC only)	
Lifting height (stroke):	67"	67"
Lifting mechanism:	Direct drive hydraulic cylinders	
Cylinder protection:	Full steel enclosure	
Clearance between carriage & vehicle:	9 1/8"	8 7/8"
Carriage movement:	Double sealed roller bearings	
Synchronization:	PLC controlled (Programmable Logic Control) keeps all columns synchronized	
Lifting forks range:	13" to 24" wheels (wider optional)	
Lifting fork height/angle:	3 1/2" and 28°	4 1/2" and 40°
Maximum tire diameter:	48" or 53" Wide Columns	
Front wheels:	6" with sealed roller bearings at center	
Steering system:	Pallet jack mechanism, handle & pressure relief valve	
Mechanical safety locks:	19 positions starting at 12"	
External hydraulic safety systems:	Pressure compensated flow control valving & velocity fuses	
Electrical safety systems:	Electronic sensors in each column	
Floor requirement:	Any hard, level surface (3° max floor slope)	
Control voltage:	24 volts	24 volts
Warranty:	3 YEARS	

Available Options

- Mobile jack stands (spring assisted)

Model	Range	Capacity per stand
JS-3047-20/30/40	30" TO 47"	20,000, 30,000 or 40,000
JS-4775-20/30/40	47" TO 77"	20,000, 30,000 or 40,000

- Chassis contact lifting beam
- Winged snow plow adapter
- Longer forks
- Wider carriages
- 460 or 575 volt power units
- Automotive frame contact adapter
- Single phase power (AC)
- Double wide columns
- 28,000 lb. fork lift adapter kit
- Slope indicator
- 24,000 and 30,000 lb. capacities available

Mohawk builds the best products with the finest materials, to the highest standards. Just compare our lifts. Our staff will assist you with any technical questions you have. We invite your calls.

Mohawk lifts are manufactured in compliance with the following standards: ALI, ANSI, ASME, AISI, ASTM, ASA, NEC, AWG, NEMA.

MEETS CURRENT NATIONAL ANSI SAFETY CODE FOR LIFTS.

MOHAWK LIFTS

Mohawk Lifts, LLC.
P.O. Box 110
65 Vrooman Ave
Amsterdam, NY 12010
(800) 833-2006
(518) 842-1431
FAX: (518) 842-1289
www.mohawklifts.com

AVAILABLE UNDER DISCOUNTED GOVERNMENT CONTRACT IN ALL 50 STATES



Mohawk MP-18 Specifications

15" FORKS

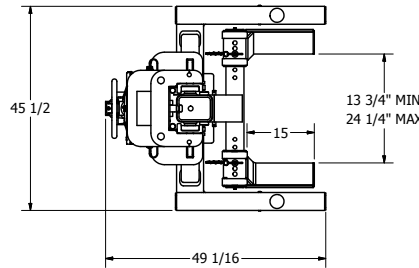

22" FORKS

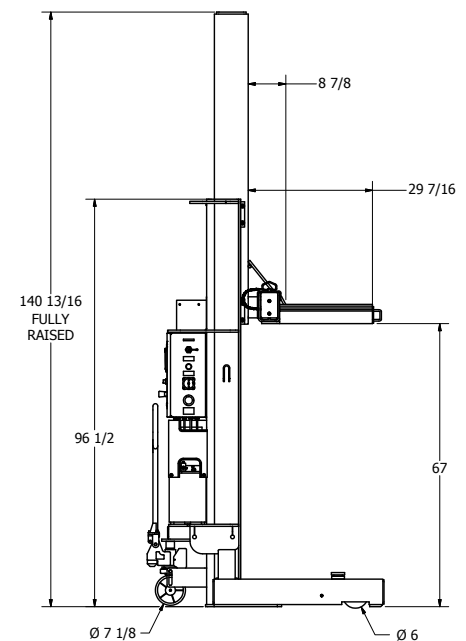
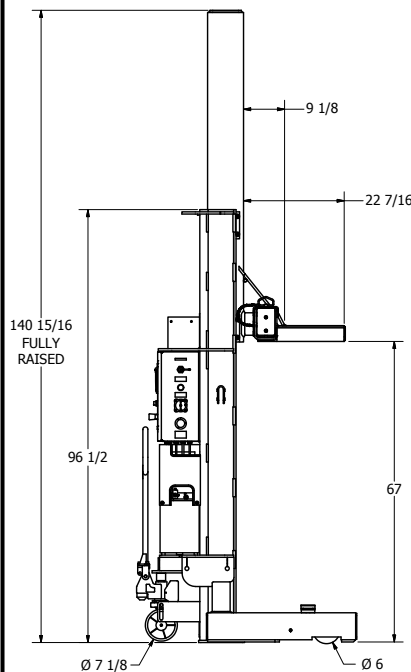
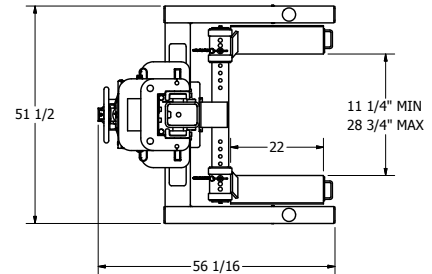

www.mohawklifts.com/specs

*Specifications subject to change without notice

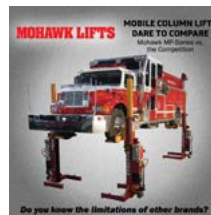

Learn how our MP Mobile Column Lifts compare to the competition.
mohawklifts.com/dare2compareMP

DISTRIBUTED BY:



Ace Service & Installation
69 Gazza Blvd.
Farmingdale, NY 11735
(631) 694-0220

www.aceshopequipment.com